

Street light circuit.

The circuit diagram present here is that of a street light that automatically switches ON when the night falls and turns OFF when the sun rises. In fact you can use this circuit for implementing any type of automatic night light.

The circuit uses an LDR to sense the light. When there is light the resistance of LDR will be low. So the voltage drop across POT R2 will be high. This keeps the transistor Q1 ON. The collector of Q1 (BC107) is coupled to the base of Q2 (SL100). So Q2 will be OFF and so do the relay. The bulb will remain OFF.

When night falls the resistance of LDR increases to make the voltage across the POT R2 to decrease below 0.6V. This makes transistor Q1 OFF which in turn makes Q2 ON. The relay will be energized and the bulb will glow.

Circuit diagram with Parts list.

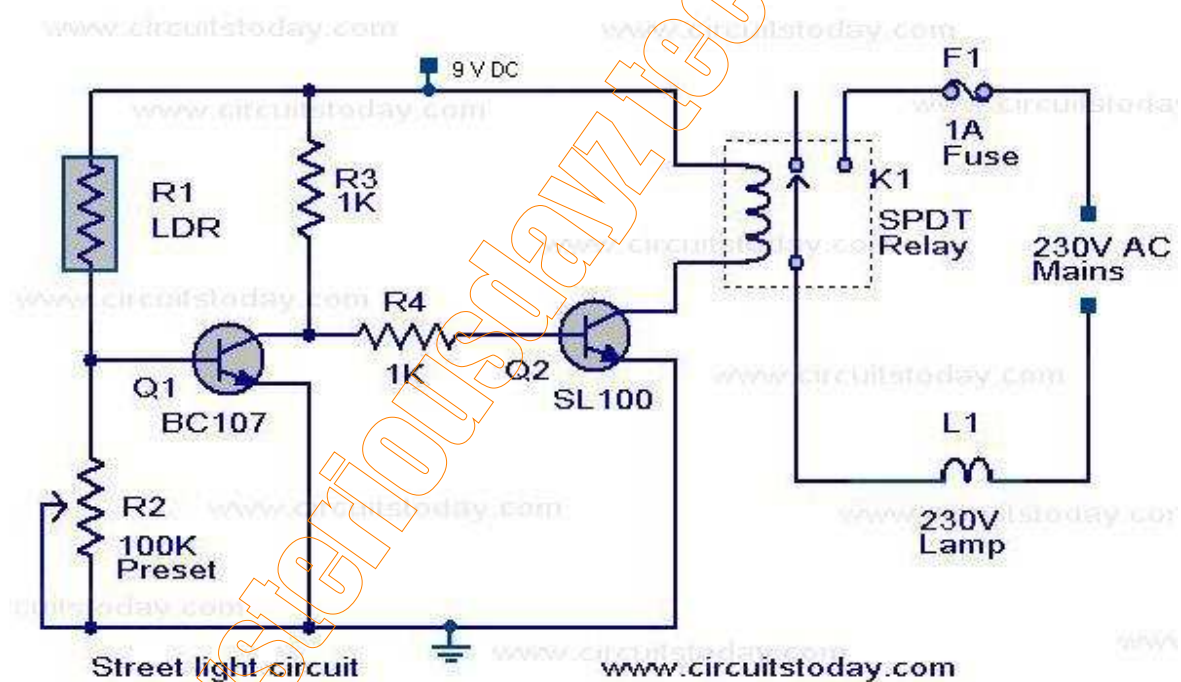

Notes.

- POT R2 can be used to adjust the sensitivity of the circuit.
- You can use bulb of any wattage, provided that relay should have the sufficient rating.
- The circuit can be powered from a regulated 9V DC power supply.